



SE572

Installation, Maintenance and Operating Instructions

Manufactured by PBA Safety in Australia to comply with AS 4775 - 2007.

DESCRIPTION

Deck mounted EMERGENCY AERATED EYE WASH unit. Eye wash is supplied with a 15mm stay open full flow ball valve, activated by an activation paddle handle. Unit swivels 90 degrees for easy access to sink when not required. Mounts to countertops up to 40mm thick.

Manufactured by PBA Safety to comply with AS 4775 - 2007

EYE/FACE WASH

Eye/Face Wash:	Aerated Eyewash
Valve:	15mm Stainless Steel
Activator:	304 Stainless Steel Push Handle

FLOW DATA

Eye/Face Wash	
Flow Pressure:	138 KPa
Flow Rate:	12 LPM

INSTALLATION

After unpacking carton, ensure all components are present. At desired location. Drill a 25mm diameter hole through countertop (40mm thick max). Be sure hole is drilled as straight as possible. Attach eyewash to countertop using supplied hardware. Fit activation handle and fasten. Once the unit is securely mounted connect water supply to 15mm male connection. Failure to use potable water can result in emergency units producing impure or contaminated water causing possible further injury. Test unit.

TESTING

The Australian Standards AS4775-2007 states that all safety equipment shall be activated on a weekly basis to flush the line and verify proper operation. All units include a testing tag to be filled out weekly.

NOTE: This unit should be connected to an uninterrupted source of potable water, no less than 15mm with a minimum flowing pressure of 138KPa and a maximum static pressure of 860 KPa.

OPERATION

The eye wash is activated by pushing the paddle handle back 90 degrees. The unit will operate until the paddle handle is manually pulled to the off position.

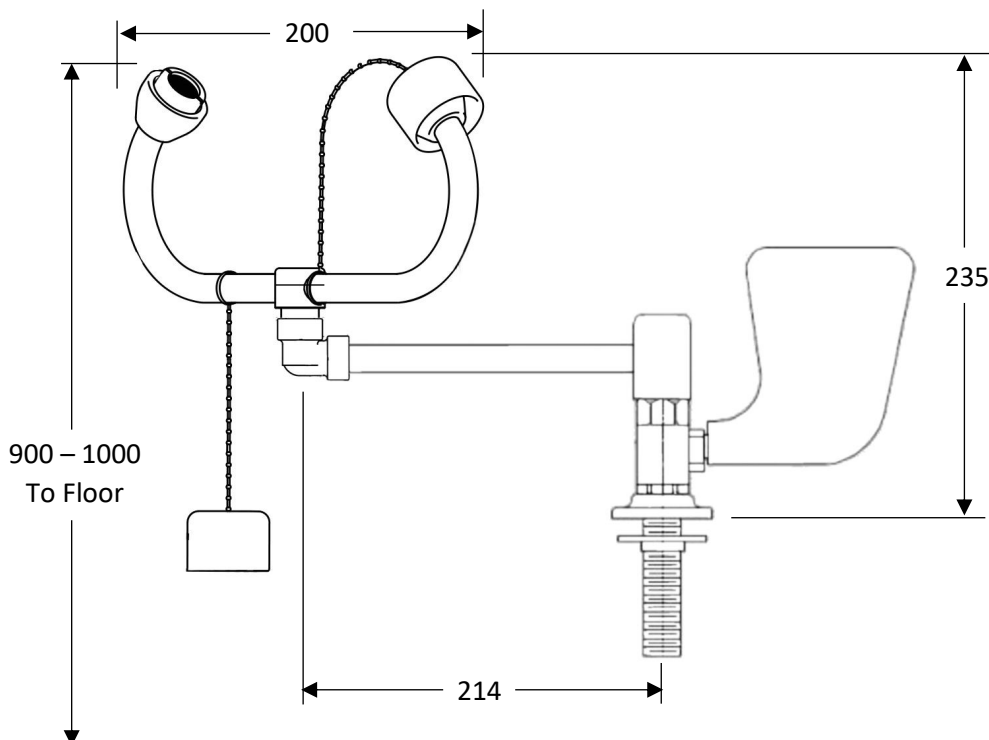
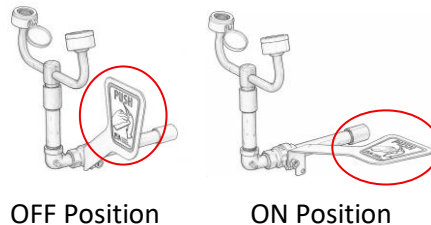

WARNING: Use only genuine Speakman parts when replacing or repairing components.

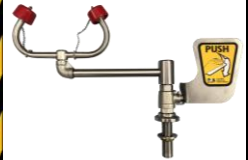

SE572
Bench Mounted Swivel
Aerated Eye Wash



Installation, Maintenance and Operating Instructions

MAINTENANCE

Should you need to repair this unit, please see the parts list for correct part numbers. Before any maintenance is done **be sure the water supply is shut off.**

MAINTENANCE SCHEDULE

Activate eyewash unit and allow water to flow for 30 seconds to flush line.

Weekly

Ensure water flows evenly from both outlets.
Ensure water is clean.

Yearly

Ensure unit complies with AS 4775 – 2007.

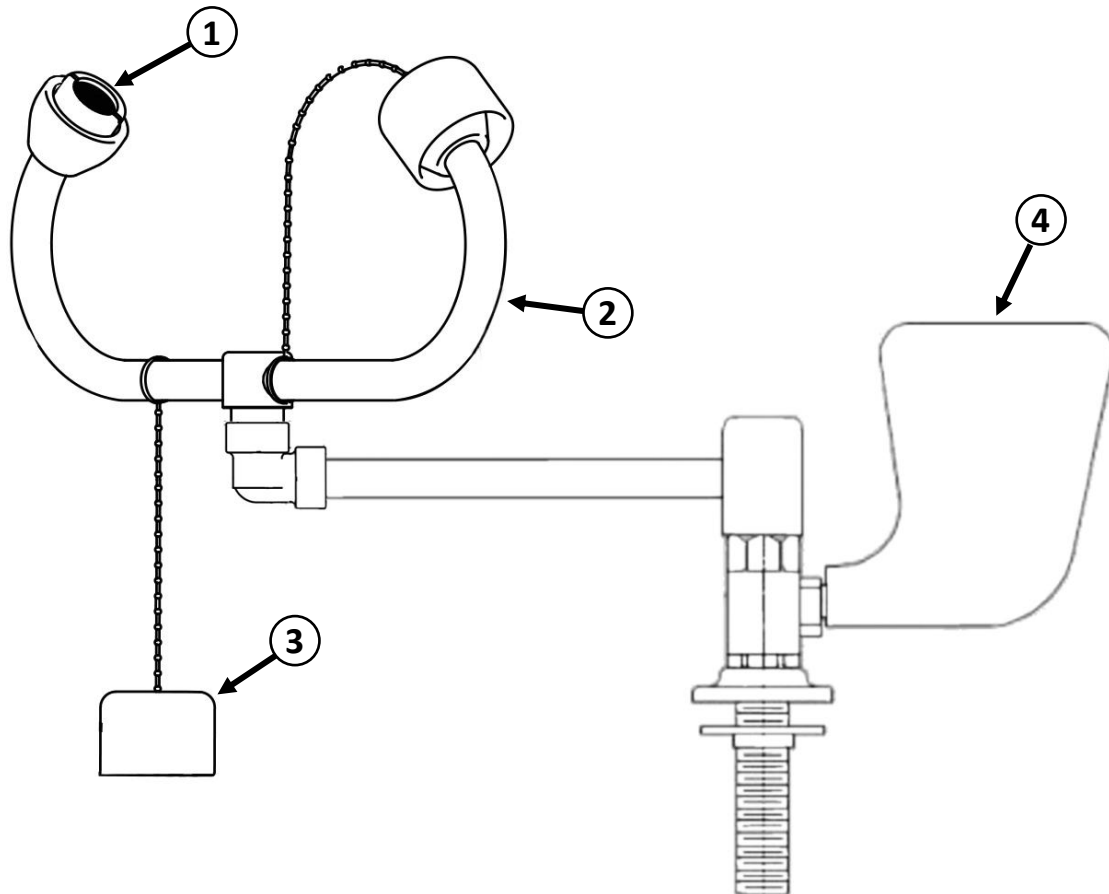

- ① **Part No: RPG05-1177**
Aerator Screen & Cap Assembly



- ② **Part No: SA 01003-572**
Complete Bulls Horns Assembly

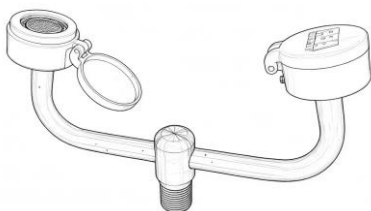

SPARE PARTS LIST

No:	Description:	Part No:
1.	Aerator, Screen & Cap Assembly	RPG05-1177
2.	Complete Bull Horns Assembly	SA 01003-572
3.	Dust Cap Assembly	SA 01008
4.	15mm Ball Valve & Push Handle	SE 910V

WARNING: Use only genuine Speakman parts when replacing or repairing components.

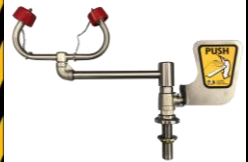

SE572
Bench Mounted Swivel
Aerated Eye Wash