



SE582 FTL

Installation, Maintenance and Operating Instructions

Manufactured by PBA Safety in Australia to comply with AS 4775 - 2007.

DESCRIPTION

Wall mounted EMERGENCY AERATED EYE WASH unit. Eye wash is supplied with a 15mm stay open full flow ball valve, activated by an activation paddle handle.

EYE/FACE WASH

Eye/Face Wash:	Aerated Eyewash
Valve:	15mm Stainless Steel
Activator:	304 Stainless Steel Push Handle
Wall Bracket:	304 Stainless Steel

FLOW DATA

Eye/Face Wash	
Flow Pressure:	138 KPa
Flow Rate:	12 LPM

INSTALLATION

After unpacking carton, ensure all components are present. Mark out the wall as per mounting bracket details. Mount the unit to the wall using suitable fasteners. Fit activation handle and fasten. Once the unit is securely mounted connect water supply to 15mm female connection. Failure to use potable water can result in emergency units producing impure or contaminated water causing possible further injury. Test unit.

TESTING

The Australian Standards AS4775-2007 states that all safety equipment shall be activated on a weekly basis to flush the line and verify proper operation. All units include a testing tag to be filled out weekly.

NOTE: This unit should be connected to an uninterrupted source of potable water, no less than 15mm with a minimum flowing pressure of 138KPa and a maximum static pressure of 860 KPa.

OPERATION

The eye wash is activated by pushing the paddle handle back 90 degrees. The unit will operate until the paddle handle is manually pulled to the off position.

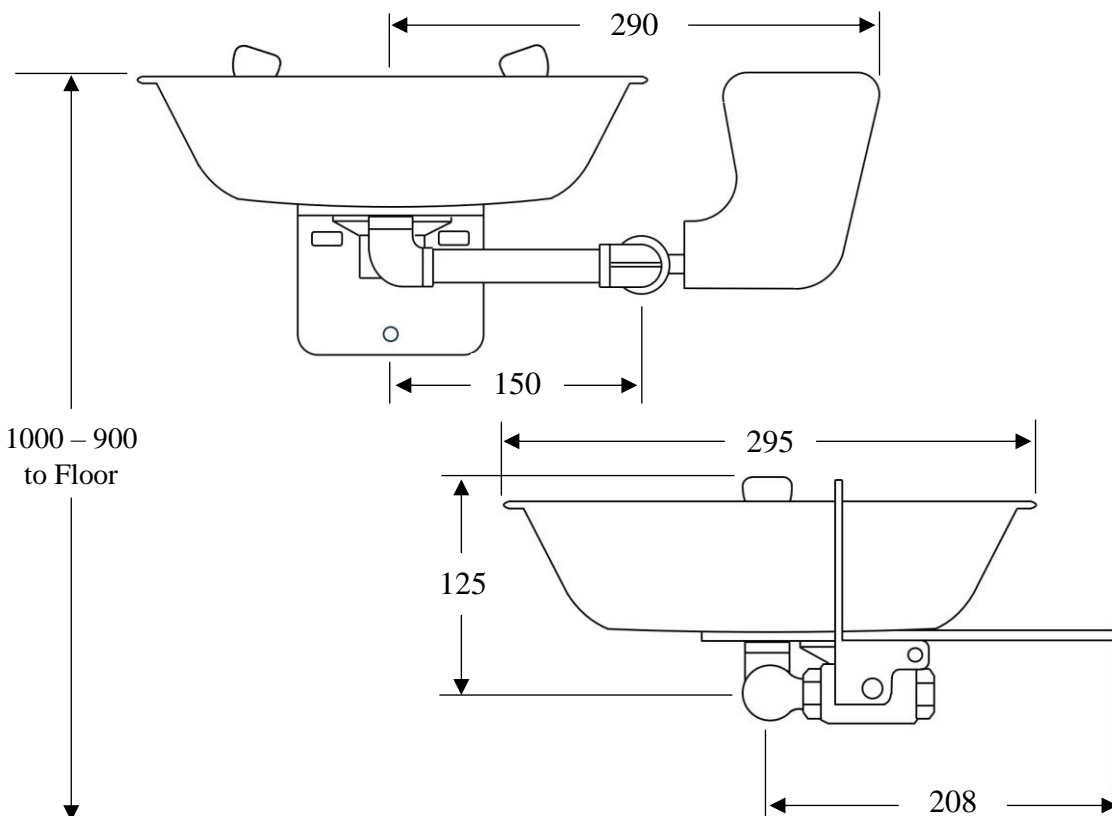
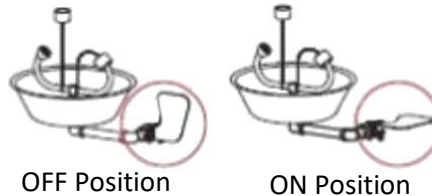

WARNING: Use only genuine Speakman parts when replacing or repairing components.

To order free call 1800 444 022 or free fax 1800 444 024



SE582 FTL
Wall Mounted
Aerated Eye Wash

Installation, Maintenance and Operating Instructions

MAINTENANCE

Should you need to repair this unit, please see the parts list for correct part numbers. Before any maintenance is done **be sure the water supply is shut off.**

MAINTENANCE SCHEDULE

Activate eyewash unit and allow water

Weekly

to flow for 30 seconds to flush line.

Ensure water flows evenly from both outlets.

Ensure water is clean.

Yearly

Ensure unit complies with AS 4775 – 2007.

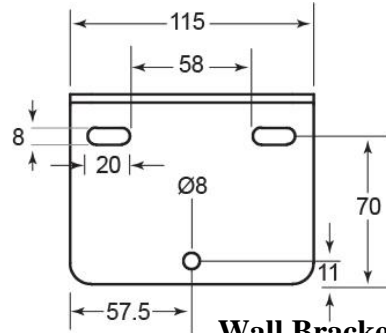

Wall Bracket Details

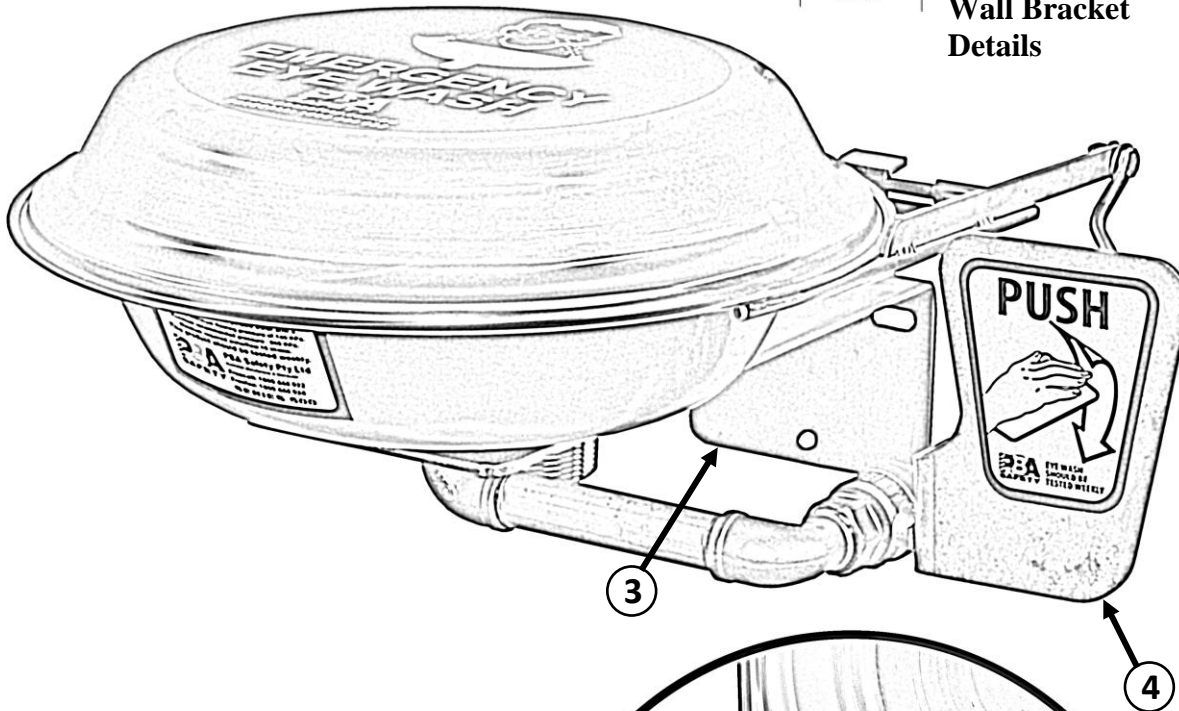

- ① Part No: RPG05-1177
Aerator Screen & Cap Assembly



- ② Part No: SA 01003
Complete Bulls Horns Assembly

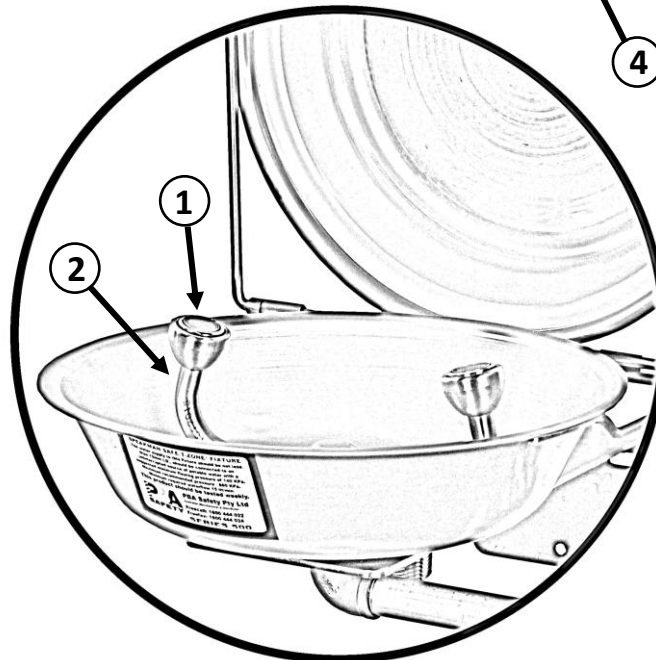
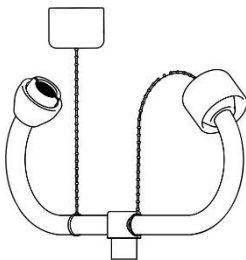

SPARE PARTS LIST

No:	Description:	Part No:
1.	Aerator, Screen & Cap Assembly	RPG05-1177
2.	Complete Bull Horns Assembly	SA 01003
3.	SE582FTL Wall Bracket	SR02032
4.	15mm Ball Valve & Push Handle	SE 910H



SE582 FTL
Wall Mounted
Aerated Eye Wash

WARNING: Use only genuine Speakman parts when replacing or repairing components.

To order free call 1800 444 022 or free fax 1800 444 024