



SE584FTL20L

Hand Operated

Installation, Maintenance and Operating Instructions

SE584HFOFTL20L

Hand & Foot Operated

Manufactured by PBA Safety in Australia to comply with AS 4775 - 2007.

DESCRIPTION

Floor mounted EMERGENCY AERATED EYE/FACE WASH unit. Eye wash is supplied with a 15mm stay open full flow ball valve, activated by an activation paddle handle and foot pedal.

EYE/FACE WASH

- Eye/Face Wash: Aerated Eyewash
- Valve: 15mm Stainless Steel
- Activator: 304 Stainless Steel Push Handle
- Base Plate: 304 Stainless Steel

FLOW DATA

- Eye/Face Wash
- Flow Pressure: 138 KPa
- Flow Rate: 12 LPM

INSTALLATION

After unpacking carton, ensure all components are present. Mark out the floor and mount the base plate using suitable anchors. Place supplied washer on top of pedestal stand. Attach bowl assembly by aligning pin on bottom of the bowl assembly with the slot on the top of the pedestal stand. Screw in drain with provided Allen key. Fit activation handle and foot pedal (SE584HFO). Once the unit is completely assembled connect water supply to 15mm BSPFemale connection.



Failure to use potable water can result in emergency units producing impure or contaminated water causing possible further injury. Test unit.

TESTING

The Australian Standards AS4775-2007 states that all safety equipment shall be activated on a weekly basis to flush the line and verify proper operation. All units include a testing tag to be filled out weekly.

NOTE: This unit should be connected to an uninterrupted source of potable water, no less than 15mm with a minimum flowing pressure of 138KPa and a maximum static pressure of 860 KPa.

OPERATION

The eye wash is activated by pushing the paddle handle back 90 degrees. The unit will operate until the paddle handle is manually pulled to the off position.

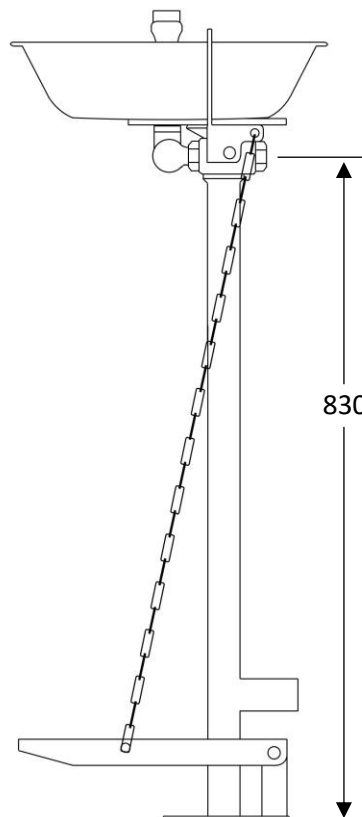
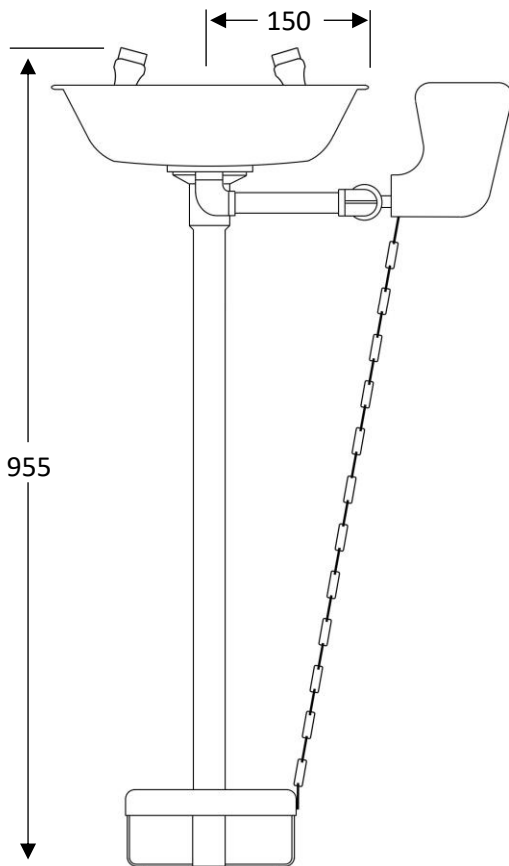

SE584HFOFTL20L / SE584FTL20L

Pedestal Mounted
Aerated Eye/Face Wash

WARNING: Use only genuine Speakman parts when replacing or repairing components.



Installation, Maintenance and Operating Instructions

MAINTENANCE

Should you need to repair this unit, please see the parts list for correct part numbers. Before any maintenance is done **be sure the water supply is shut off.**

MAINTENANCE SCHEDULE

Activate eyewash unit and allow water

Weekly

to flow for 30 seconds to flush line.

Ensure water flows evenly from both outlets.

Ensure water is clean.

Yearly

Ensure unit complies with AS 4775 – 2007.

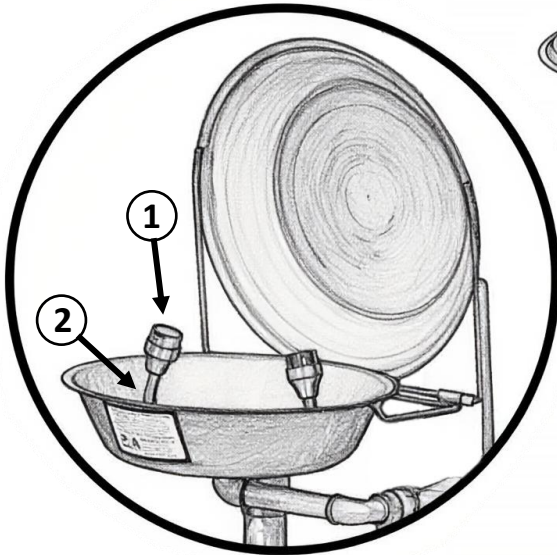

- ① **Part No: SR 06013**
Aerator & Cap Assembly 25mm DIA



- ② **Part No: SA 01014**
Bull Horns Assembly 20L/Min

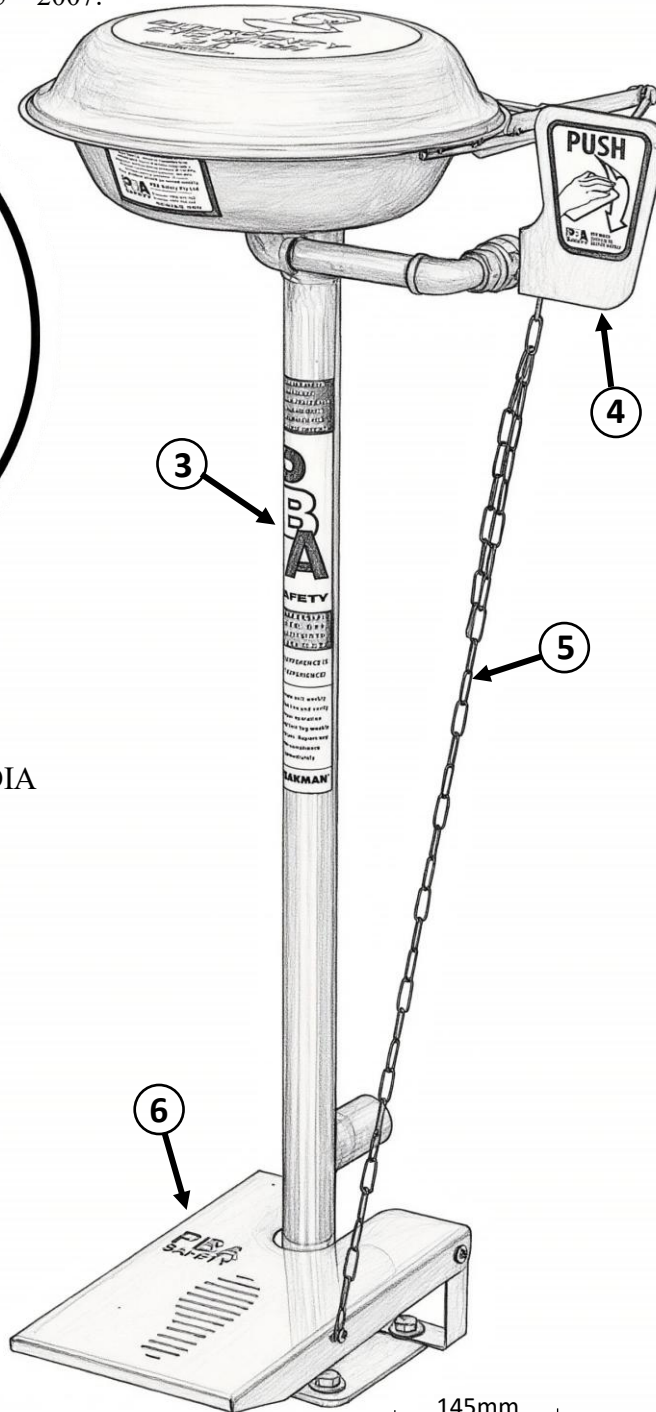
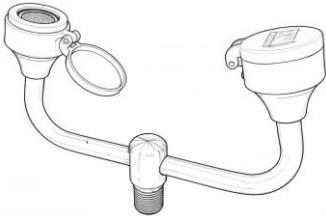

SPARE PARTS LIST

No:	Description:	Part No:
1.	Aerator, Screen & Cap Assembly	SR 06013
2.	Complete Bull Horns Assembly	SA 01014
3.	Pedestal Frame	SA 01001
4.	15mm Ball Valve & Push Handle	SE 910H
5.	Foot Pedal Connection Chain	SA 03014
6.	Foot Pedal Assembly	SA 03001

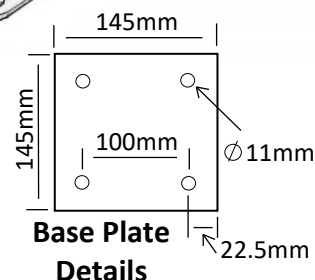

SE584HFOFTL20L / SE584FTL20L

Pedestal Mounted
Aerated Eye/Face Wash