

## HAT/SP

# SCALD PROTECTION VALVE

## BENEFITS

- HAT/SP temperatures up to 105°F meet ANSI Z258.1 standards
- Protects safety showers from over-temperature conditions, keeping personnel safe
- Long service life
- Fast response
- Discharges the minimum amount of water required

## DESIGN FEATURES

- Stainless steel body, fittings, spring, and plug
- Corrosion resistant
- Exclusive Thermoloid® sensor/controller
- Compact, low-mass
- Two wrench flats for easy installation
- Ram type plug for reliable and tight shutoff
- Installs in any orientation

## APPLICATIONS

A safety hazard for plant personnel will occur through solar radiation or overheating caused by steam or electric tracing resulting in extremely high temperatures at the point of use. The HAT/SP valve prevents this safety hazard. When installed in safety showers, eyewash stations, and other locations exposed to the same source of overheating as the system, the HAT/SP will be heated just as the pipe system. The valve will open to establish flow until the over-temperature water is eliminated and it will then modulate closed.

## OPERATION

The HAT/SP-105 will initiate flow when the thermostatic actuator senses 98°F (36.7°C) and will remain open as long as the discharge water temperature is above 95°F (35°C).

When installed in the ambient sensing position (standard flow), the actuator will respond to ambient temperature to initiate flow and then respond to water temperature once flow is established; when installed in the fluid sensing position (reverse flow), the actuator will always respond to water temperature.



## SAMPLE APPLICATION

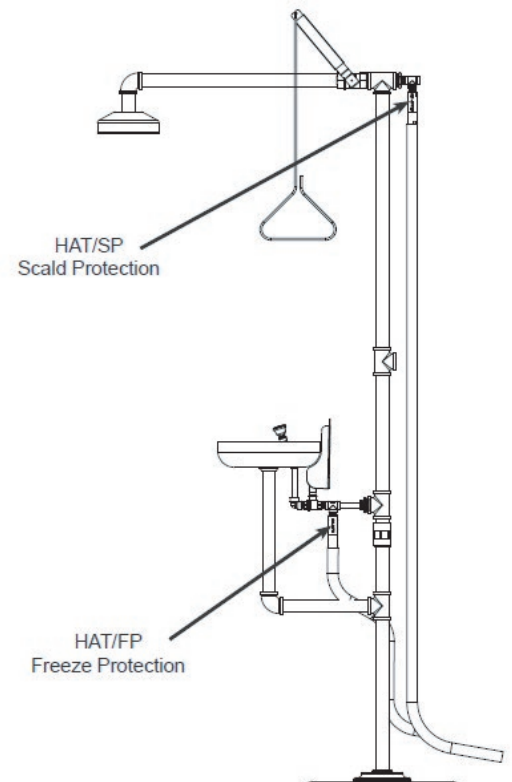

HAT/SP

**SCALD PROTECTION VALVE**

**PARTS & MATERIALS**

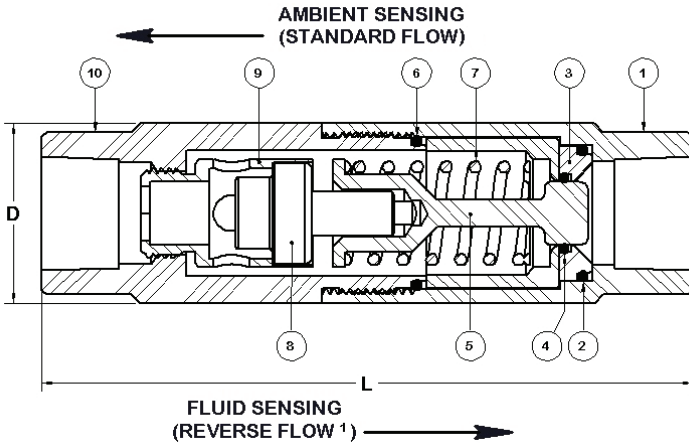

ITEM	DESCRIPTION	MATERIAL
1	BODY - HALF	300 Series SS
2	SEAT INSERT SEAL	EPDM
3	SEAT INSERT	300 Series SS
4	SEAT SEAL	FEP Encapsulated Viton
5	RAM-TYPE PLUG	300 Series SS
6	BODY SEAL	EPDM
7	OPERATING SPRING	300 Series SS
8	THERMAL ACTUATOR	Brass or 300 Series SS
9	ACTUATOR CARRIER	Brass or 300 Series SS
10	BODY - HALF	300 Series SS

**DIMENSIONS & CAPACITIES**

SIZE (NPT)	D		L		Weight		Port Size	C <sub>v</sub>	Maximum Operating Pressure <sup>1</sup>	Maximum Temperature
	in	mm	in	mm	Lb	Kg				
1/2"	1.3	33	4.5	114	0.9	0.4	C	1.5	200 PSIG (13.8 BAR)	300°F (149°C)
3/4"	1.5	38	5.5	140	1.4	0.6	D	2.0		

**NOTES**

1. Reverse flow option for C-port is rated 150 PSIG (10.33 BAR); D-port is 70 PSIG (4.8 BAR)
2. Full open temperature, "XXX", is 105°F. Optional full open temperatures, "XXX": 95°F, 100°F, 110°F, and 115°F.
  - a. Note: Closing temperature is typically 10°F below opening temperature.
3. A #20 mesh strainer is recommended.