



SE663 PO

Platform Operated Shower & Hand Operated Eye/Face Wash Installation, Maintenance and Operating Instructions

Manufactured by PBA Safety in Australia to comply with AS 4775 - 2007.

DESCRIPTION

Platform activated Combo 16 Multi Spray Head Decontamination unit, each spray head has a separate volume control. Unit comes complete with a hand activated Eye/Face Wash, supplied by a 15mm stay-open full flow ball valve.

SHOWER

Spray Heads: (16) 40mm Brass Nickle-Plated
Valve: 40mm Female Brass
Activator: Galvanized Grate
Pipe: 25mm 304 Stainless Steel

EYE/FACE WASH

Eye/Face Wash: Triple Aerated Shrouds
Valve: 15mm Stainless Steel
Activator: 304 Stainless Steel Push Handle

INSTALLATION

Unpack and place unit in desired location, and secure using suitable anchors. Unscrew eyewash from inside of unit and move it to the outside of unit. Resecure eyewash and attach copper connection. Connect a water supply to the unit (use thread sealant on all joints). Ensure unit has an uninterrupted source of potable water. Failure to use potable water can result in emergency units producing impure or contaminated water causing possible further injury. A drain or waste may be connected in compliance with local plumbing codes, if required.

TESTING

The Australian Standards AS4775-2007 states that all safety equipment shall be activated on a weekly basis to flush the line and verify proper operation. All units include a testing tag to be filled out weekly.

NOTE: This unit should be connected to an uninterrupted source of potable water, no less than 25mm with a minimum flowing pressure of 138KPa and a maximum static pressure of 860 KPa.

OPERATION

The shower is activated by stepping onto the platform and will then continue to operate until the user steps off when the unit is no longer required.

The eye wash is activated by pushing the paddle handle back 90 degrees. The unit will operate until the paddle handle is manually pulled to the off position.



OFF Position



ON Position

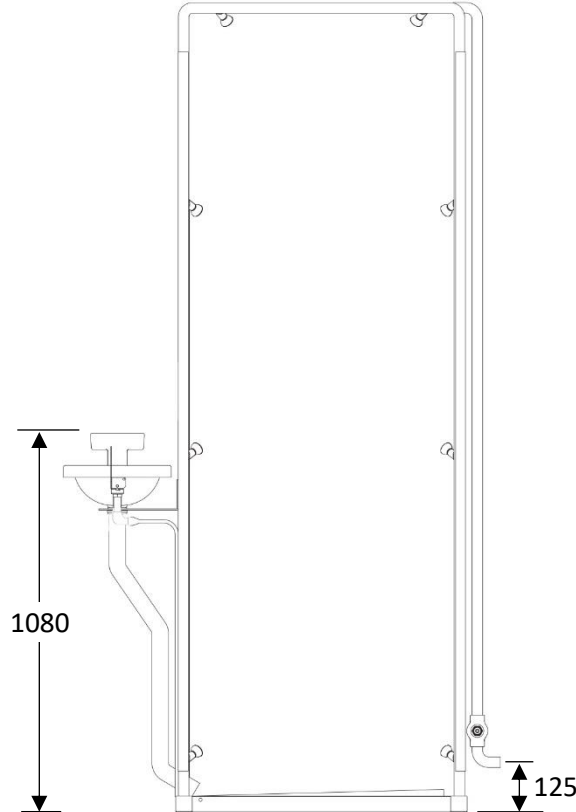
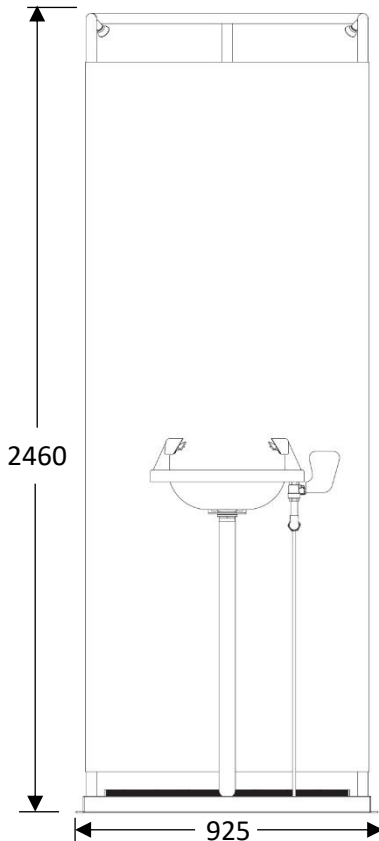

SE663 PO
Platform Operated Multi Spray Shower
w/ Aerated Eye/Face Wash

WARNING: Use only genuine Speakman parts when replacing or repairing components.

To order free call 1800 444 022 or free fax 1800 444 024



Installation, Maintenance and Operating Instructions

MAINTENANCE

Should you need to repair this unit, please see the parts list for correct part numbers. Before any maintenance is done **be sure the water supply is shut off.**

MAINTENANCE SCHEDULE

Activate eyewash unit and allow water to flow for 30 seconds to flush line.

Weekly

Ensure water flows evenly from both outlets. Ensure water is clean.

Yearly

Ensure unit complies with AS 4775 – 2007.

- ① **Part No: RPG05-1177**
Aerator Screen & Cap Assembly



- ② **Part No: G10-0041**
Shroud Body Repair

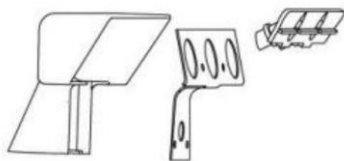

- ③ **Part No: G10-0042**
Complete Shroud Assembly

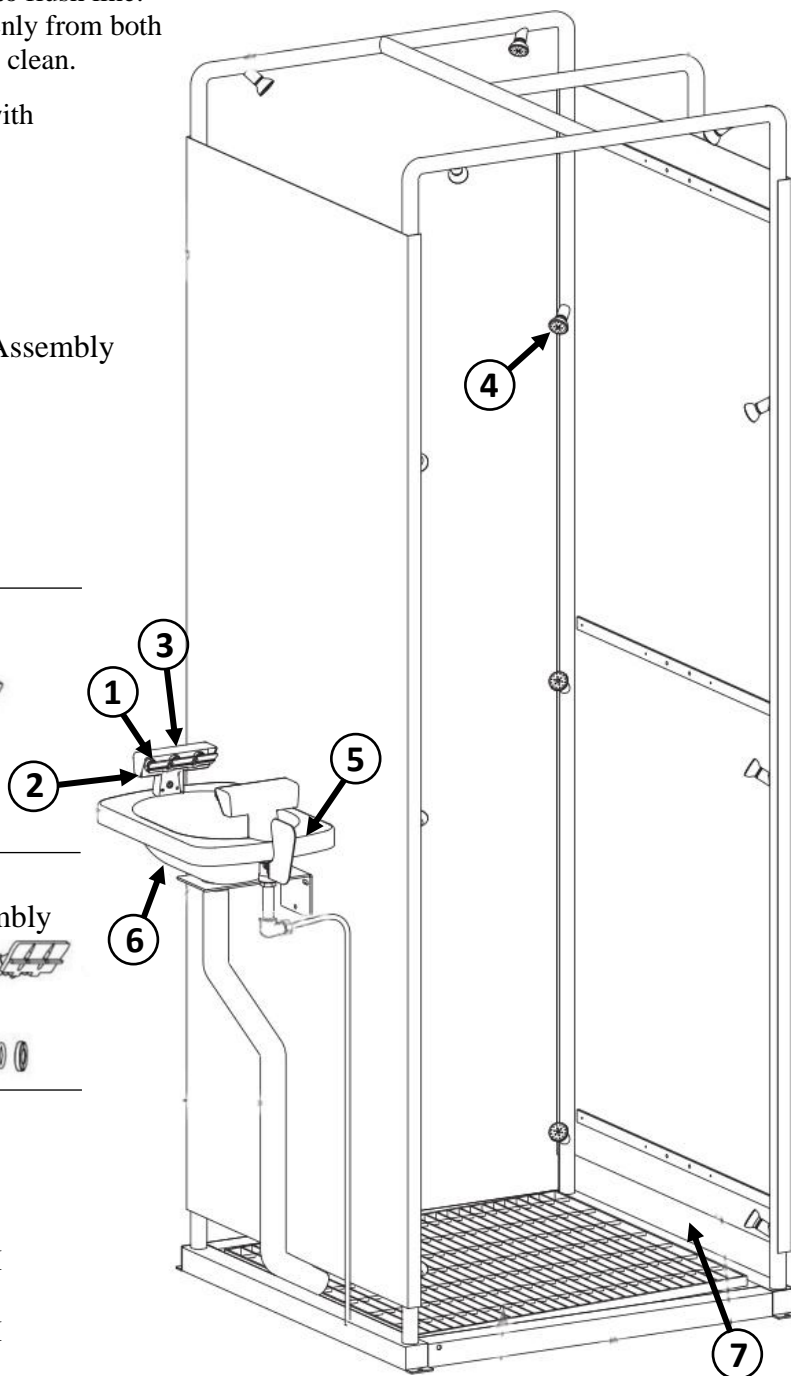
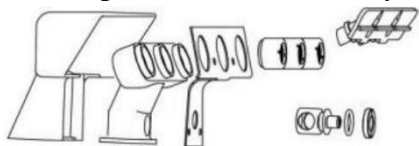

FLOW DATA

Eye/Face Wash

Flow Rate: 36 LPM

Shower

Flow Rate: 240 LPM

SPARE PARTS LIST

No:	Description:	Part No:
1.	Aerator, Screen & Cap Assembly	RPG05-1177
2.	Shroud Body Repair Kit	G10-0041
3.	Complete Shroud Assembly	G10-0042
4.	Multi Spray Head Assembly	G38-0012-RCP
5.	15mm Ball Valve & Push Handle	SE 910V
6.	Stainless Steel Bowl	68-0033
7.	40mm Platform Operation Valve	SE902

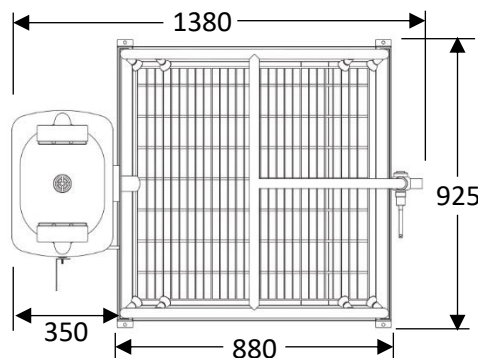

SE663 PO
Platform Operated Multi Spray Shower
w/ Aerated Eye/Face Wash

WARNING: Use only genuine Speakman parts when replacing or repairing components.

To order free call 1800 444 022 or free fax 1800 444 024